

Leica

MICROSYSTEMS

Leica D*M*i8 M / C / A

Invert the Game – And Stay Ahead

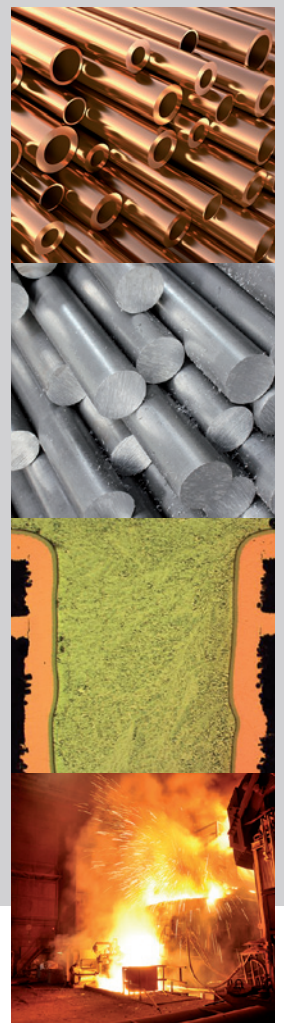

Premium Compound Microscope for Industrial Applications

The Name of the Game: Speed and Efficiency!

Your team strives for the best results, every day. Being one step ahead of the competition is what counts in your business. Whether you work in metallography, medical device manufacturing, or microelectronics, efficiency is essential. Discover how the Leica DMI8 microscope platform can be the winning component.

SPEED UP YOUR PROCESS WITH INVERTED MICROSCOPY

Achieve **higher sample throughput** by working with an inverted microscope. Unlike upright microscopes you simply place your sample on the stage, focus onto the surface once, it remains in focus for all magnifications and additional samples. Sample switching can be **up to four times faster**.

You benefit from a **large working space** to easily position even huge and heavy samples. The inverted microscope enables you to work with **samples that weigh up to 30 kg**. Additionally, you save time as cutting and embedding of samples are not necessary.

STAY FLEXIBLE! THE MODULAR DESIGN

With the freedom of a completely **modular system**, you can create the perfect tool for your work. Tailor the Leica DMI8 to **fit your budget, application needs, and preferences**. You can choose between manual, coded, and automated functions. Invest in the features you need now – and be prepared for future requirements.

Take advantage of:

- › Range of contrast modes for all application needs, including the **unique Ultra-Contrast 3D illumination**
- › **Exclusive macro* objective** from Leica Microsystems allowing you to get up to **four times more field of view** (35 mm in one glance) compared to standard overview objectives.

GUIDED WORKFLOW: HIGH-END MICROSCOPY FOR EVERYBODY

The Leica DMI8 makes it **easy to achieve accurate results** – for everybody on your team. The “guided microscopy concept” uses:

- › Leica Application Software (LAS)
- › LED signs and function keys that you can program according to your preferences
- › Touch screen

Coded components offer ease of use and reliable results even for untrained operators. The illumination manager **supports you by adjusting the light intensity** to optimally fit your sample. The contrast manager ensures fast and easy change between contrast modes.



LEARN | SHARE | CONTRIBUTE

Want to read more about the advantages of inverted microscopy?
www.leica-microsystems.com/science-lab

* Not available in Japan

- 1: Grey cast iron with graphite flakes PI. Fluotar 100x BF, 100x DIC + UC 3D
- 2: Macro system
- 3: Leica Application Suite (LAS) Steel Expert



The Leica DMi8 offers you an incredible amount of options. To help you decide, Leica Microsystems has developed a range of solutions to match different applications and budgets.

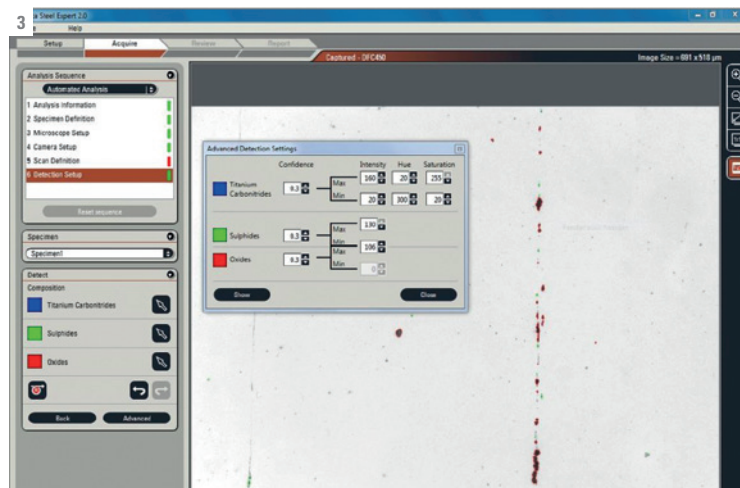
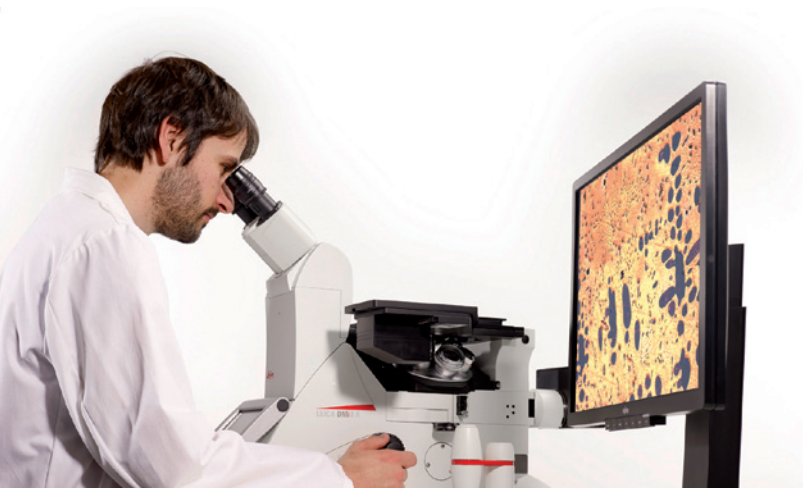
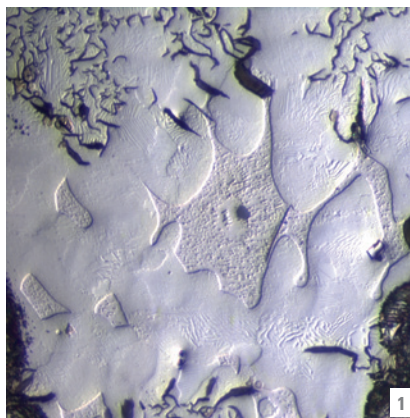
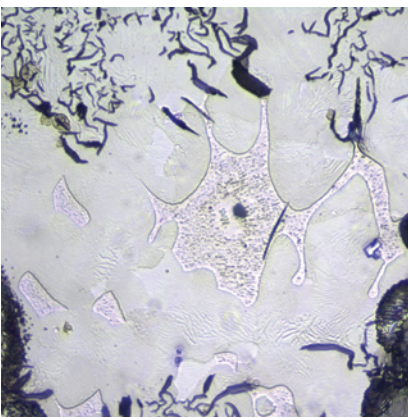

Leica DMI8 M

The Easy Way to Stay Ahead

Do you need a system for a routine, dedicated task? Are you looking for a cost-efficient and robust tool? The Leica DMI8 M is the solution for the production environment or for highly specialized Brightfield inspection applications. Easy to use, affordable, yet without compromising quality. The results of this manual microscope solution are the best proof.

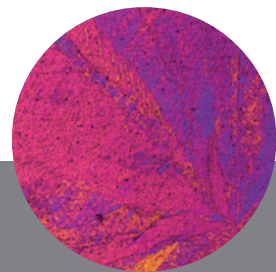
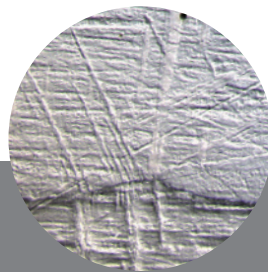

Zinc: Pl. Fluotar ● 5x BF ● 5x UC-3D ● 5x DIC ● 5x DIC + UC-3D ● 5x Pol. lambda plate

LED ILLUMINATION FOR A RANGE OF APPLICATIONS

LED illumination supports all contrast modes and opens the Leica DMI8 to a broad range of applications. With the LED's white light you work with a constant color temperature of 4,500 K. This allows you to see your **sample in true color even at low voltages**. Lower power consumption and the LED's approx. 20,000 hours service life makes lamp replacements unnecessary.

GET MORE INFORMATION THANKS TO VARIOUS CONTRAST MODES

Focus on what you really need for your analysis: Inspect your sample in Brightfield (BF), Polarization (POL), and Differential Interference Contrast (DIC). **Get additional surface information** through the unique Ultra-Contrast 3D (UC 3D) illumination. With these integrated illumination solutions **you see more faster**.

DESIGN YOUR HIGHLY SPECIALIZED BRIGHTFIELD SOLUTION

Discover the finest structures with apochromatic color correction. All you need to do is combine the Leica DMI8 M with high quality Plan Apo objectives. You benefit from seeing more details, and nothing remains hidden.

Leica DMI8 C

The Code to Reliability and Speed

The coded components of the Leica DMI8 ensure that all images you take are always calibrated for reproducible and reliable results.

INTELLIGENTLY LINKED COMPONENTS

The Leica DMI8 C features a coded 6-fold Darkfield/Brightfield nosepiece, filter turret, DIC mode, and magnification changer. **Intelligently linked** with each other, they allow you to change settings without having to manually adjust the calibration. This ensures **faster operation, fewer errors**, and thus **reliable data**.

SIX-IN-ONE-SWEEP NOSEPIECE

The coded 6-fold Darkfield nosepiece makes it **easy to change between magnifications**. By switching from macro to micro without the need to swap objectives, you **save precious time**.

DELIVER BRILLIANT RESULTS

Change between contrast modes and magnifications as often as you need – and **be confident that you are using the correct** illumination intensity. The illumination manager automatically adjusts the light intensity according to the chosen mode.

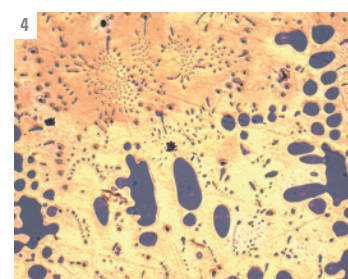
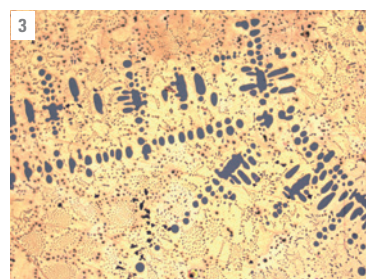
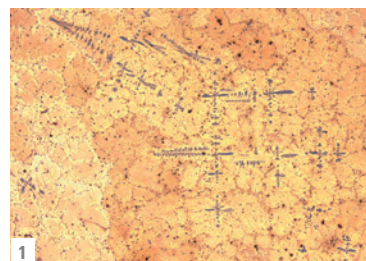



1



2

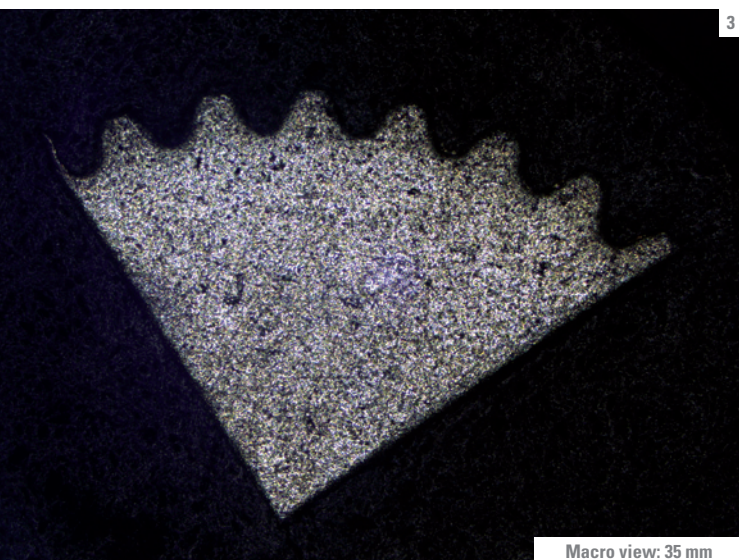

3

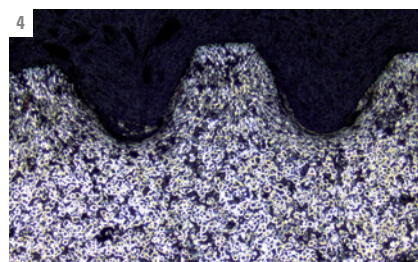

4

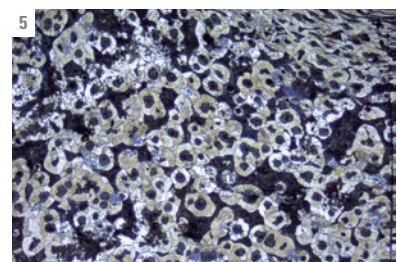

5

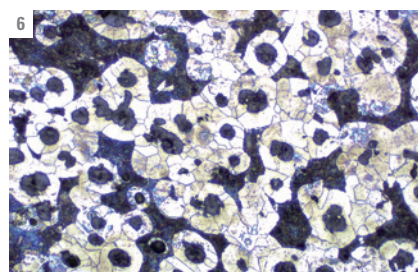

6

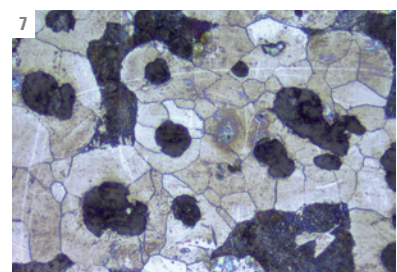

7

Macro view: 35 mm

Leica DMI8 A – The Automated Allrounder

The automated Leica DMI8 A is the tool of choice for demanding research applications and for novice operators alike. The automated features help to increase efficiency, create precise and reproducible data, and minimize the risk of errors.

FROM MACRO* TO NANO WITH JUST ONE CLICK

The Leica DMI8 A has a motorized micro/macro mode for rapid scanning and screening of large components. Switch **from macro (35 mm) to nano (1 nm)** with one click. With the macro mode you get an overview of 35.7 mm – that is **four times the field of view** compared to conventional objectives. Change between different magnifications – 0.7x - 5x - 10x - 20x - 50x - 100x – and conveniently illuminate your sample from different angles.

ONE BUTTON OPERATION FOR DIC

Choose DIC with just one click. The analyzer, polarizer, and appropriate prism for the objective automatically move into the optical path. The Leica DMI8 A **reliably adjusts illumination intensity, aperture, and field stop**. This helps to avoid mistakes.

INDIVIDUAL FUNCTIONS SUPPORT YOUR WORKFLOW

Program the function keys with **the functions you use most**. For example, choose the macro mode for a quick overview, 10× Brightfield (BF) for a detailed view, 20× Darkfield (DF) for structured information, and reserve one button for documentation. Customized function keys help to **speed up your workflow**.

COMPLIANCE TO COMMON STANDARDS

The Leica DMI8 A ensures **reliable results** even for applications with strict specifications. For example, the size of the field stop results in a (710 × 710 μ) field of view corresponding to the relevant **standards ASTM E45, ISO 4967, and EN 10247** for non-metallic steel inclusion rating.

AT FULL SPEED WITH INTELLIGENT AUTOMATION

The Leica DMI8 A makes changing between contrast methods and objectives fast and smooth. Choose a specific contrast mode, and **in less than one second** all components move into the light path. Plus, the microscope **automatically adapts the illumination settings, parfocality, brightness, and diaphragm position** to that mode. This ultra-easy operation helps avoid errors and saves time.

INTUITIVE HANDLING FOR FASTER WORK

The touchscreen is positioned at the front of the microscope and displays your settings. It serves as a control unit for all motorized and coded functions. Being user-friendly and intuitive, it **reduces training time with clear, easy-to-follow controls** and instrument status information. Moreover, you can personalize the function keys to your preferences.

* Not available in Japan

1, 2: Illumination manager, Focus control & control buttons

3-7: Cast iron with globular graphite PI. Fluotar Macro 0.7x BF, 2.5x BF, 10x BF, 20x BF, 50x BF

The Open Leica DMI8 Platform – Open to Your Ideas

Use the open microscope platform to adapt it to your specific tasks. Leica Microsystems invites you to create your personal version of the Leica DMI8. You have all the functions at your fingertips to stay ahead – and the option to add the components you may require in the future. All of the suggested configurations in this brochure are available as open platform to support your work.

MAXIMUM FLEXIBILITY FOR YOUR WORK

Do you need to analyze a big and heavy sample? Or need your microscope to be built into the production line? The open platform of the Leica DMI8 allows you to do just that. The **digital microscope version comes without eyepieces**, but displays the image on a monitor. This enables you to work in an **ergonomic position** and **improve productivity**.

SOFTWARE THAT SUPPORTS YOUR ANALYSIS TASKS

Leica Application Suite (LAS) offers a variety of modules to suit your needs and **make your workflow efficient**. Steel Expert, Phase Expert, or Grain Expert are only a few of the dedicated software solutions. **Regular updates and upgrades** of LAS and its modules ensure that you are always ahead of the game.

CHANGE YOUR PERSPECTIVE WITH UC 3D ILLUMINATION

This exclusive illumination solution from Leica Microsystems is an indispensable tool **for examining sides, edges, or chipping**. It allows you to illuminate a sample from different angles, obtain additional information on the surface structure, and achieve improved contrast. It is an easy and **cost-effective way to visualize topographies**.

REVEAL HIDDEN DETAILS WITH HIGH DEFINITION DARKFIELD

High-definition Darkfield (HDF) contrast **reveals details of the sample with greater intensity** and clarity than conventional optical techniques. Even the finest structures become visible. Compared with conventional Darkfield objectives, the **working distance is almost twice as large**. This protects the sample and the front lens, and hence your investment.

1: Digital microscope solution

2: Darkfield analysis

3, 4: Ski pole Pl. Fluotar 5x UC 3D, 5x HDF



1

2

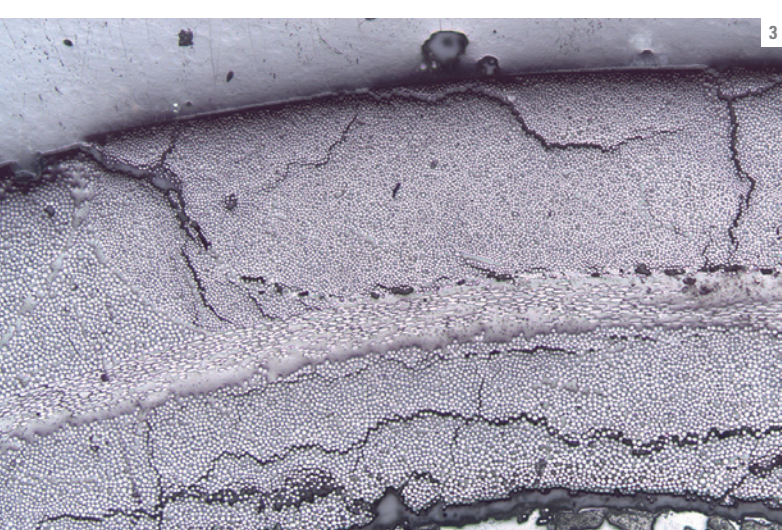
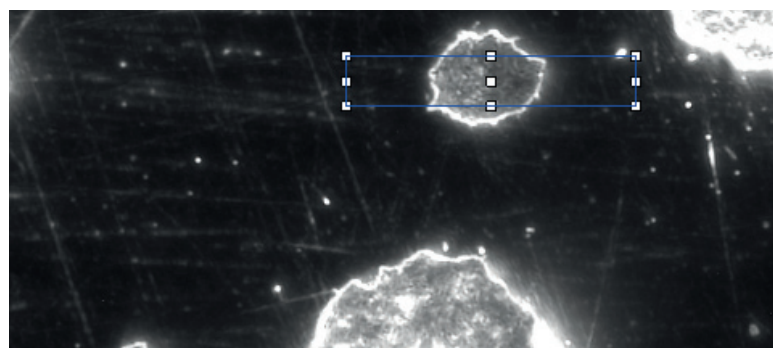
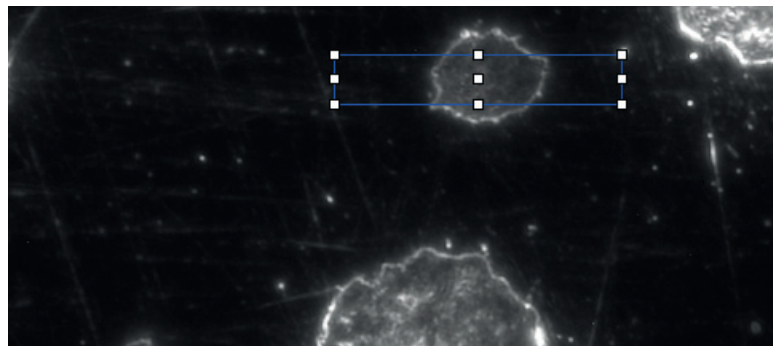
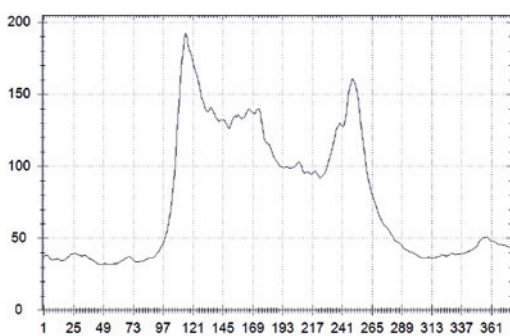
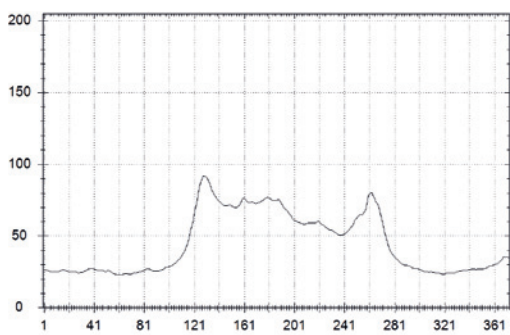

3

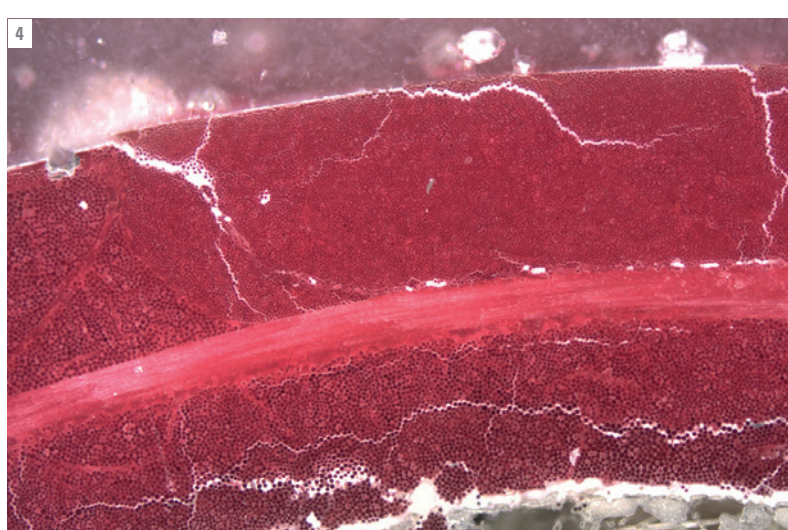

4

Dimensions

Leica DMI8 (without transmitted light arm)

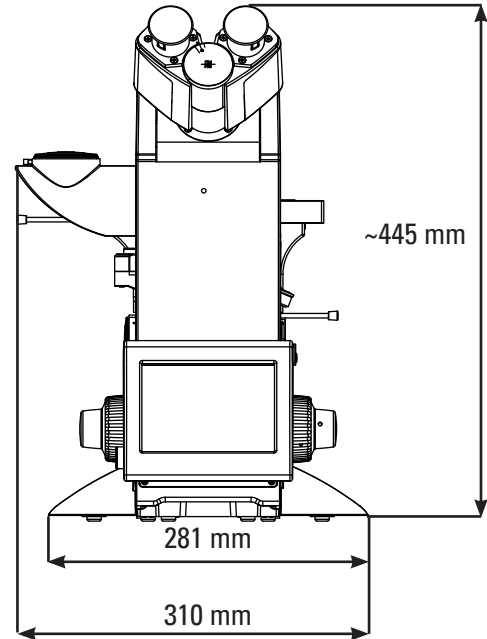
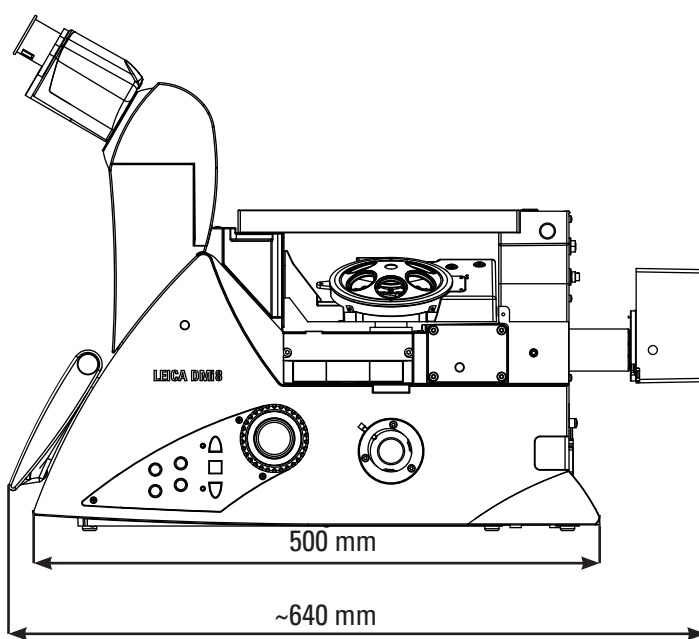

Leica DMI8 (with tiltable transmitted light arm)

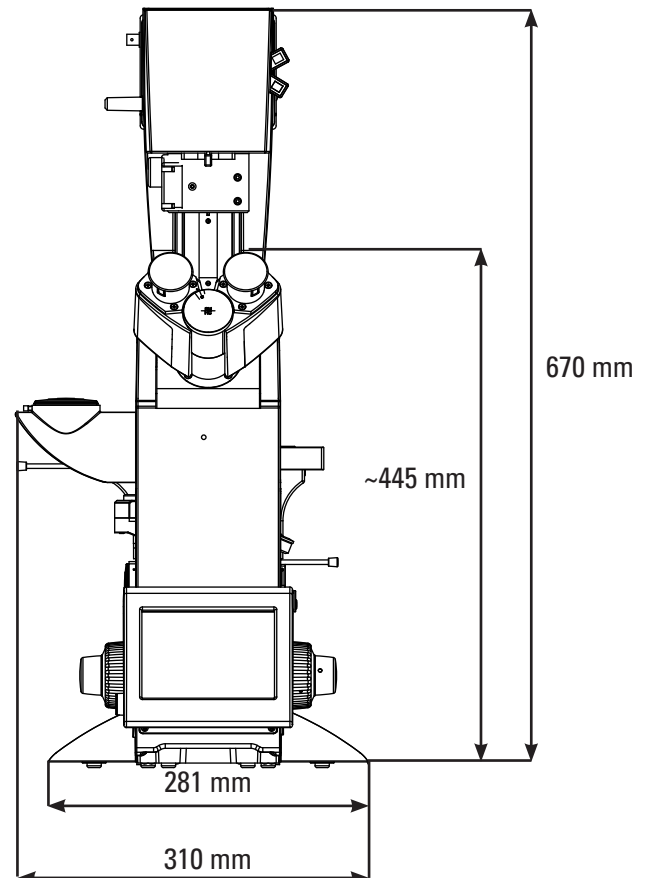
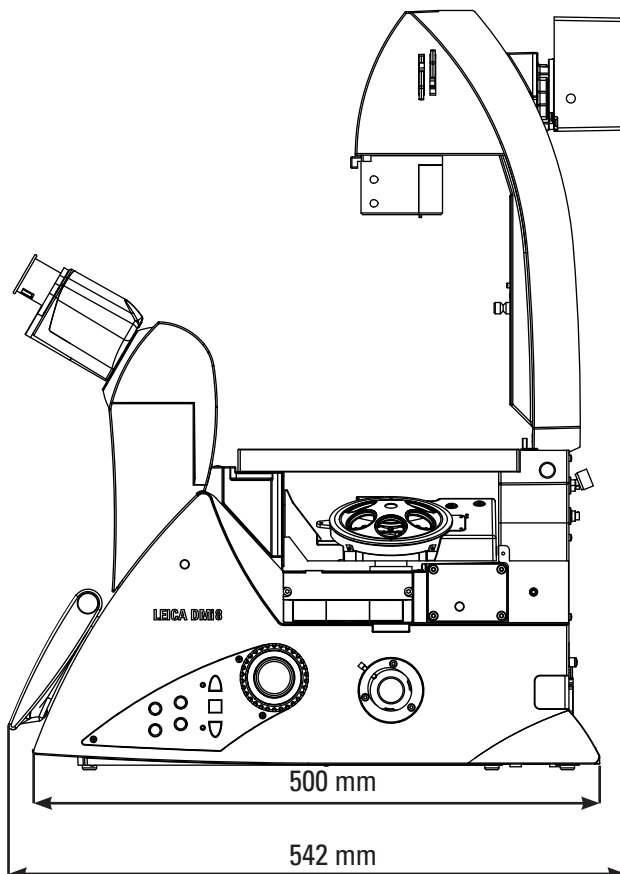

Specifications

	LEICA DMI8 M	LEICA DMI8 C	LEICA DMI8 A
STAND			
Power supply	Internal	Internal	Electronic box CTR basic or CTR advanced
Display		6 or 12 LEDs	Options: LEDs, function keys, touchscreen
FOCUS			
	<ul style="list-style-type: none"> Manual 2-gear 	Options: <ul style="list-style-type: none"> Manual 2-gear Manual 3-gear with focus stop and torque adjustment 	Options: <ul style="list-style-type: none"> Motorized Manual 3-gear with focus stop and torque adjustment
OBJECTIVE TURRET			
	<ul style="list-style-type: none"> 6-fold M25 	Options: <ul style="list-style-type: none"> 6-fold M32 coded 6-fold M25 coded 	Options: <ul style="list-style-type: none"> 6-fold M32 motorized 6-fold M32 coded 6-fold M25 motorized 6-fold M25 coded
REFLECTOR TURRET			
	Fixed BF-splitter	<ul style="list-style-type: none"> 2-fold reflector turret coded 6-fold reflector turret coded 6-fold reflector turret uncoded 	<ul style="list-style-type: none"> 6-fold reflector turret motorized 2-fold reflector turret coded 6-fold reflector turret coded 6-fold reflector turret uncoded
REFLECTED LIGHT AXIS			
	Manual incl. centerable field and aperture iris diaphragm and manual UC 3D illumination, slot for polarizer and additional filter slider	Manual incl. centerable field and aperture iris diaphragm and manual UC 3D illumination, slot for polarizer and additional filter slider	Options: <ul style="list-style-type: none"> Motorized incl. centerable field and aperture pinhole illumination, slot for polarizer and additional filter slider Manual incl. centerable field and aperture diaphragm and UC 3D illumination, slot for polarizer and additional filter slider
CONTRAST TECHNIQUES			
Incident light (IL)	BF, UC 3D, DIC, Pol	BF, UC 3D, HDF, DIC, Pol, Fluorescence	BF, UC 3D, HDF, DIC, Pol, Fluorescence
Transmitted light (TL)		BF, Pol, Ph, DIC, DF	BF, Pol, Ph, DIC, DF
MAGNIFICATION CHANGER			
		Active on front port, manual coded: 1.5× or 2.0×	Active on all ports, motorized: 1.5× and/or 2.0×
CONTROL ELEMENTS			
Stand	Intensity control	<ul style="list-style-type: none"> Intensity control IL/TL switch 	Options, dependent on configuration: <ul style="list-style-type: none"> Function keys on front panel Touchscreen Left: light and contrast manager Right: 4 freely programmable function keys, focus control
Smart Move			<ul style="list-style-type: none"> Control element for focus and stage movement 4 freely programmable function keys
STP4000			<ul style="list-style-type: none"> External 6" touchscreen
STP8000			<ul style="list-style-type: none"> External 6" touchscreen with xyz control and 11 freely programmable function keys
STAGE			
	<ul style="list-style-type: none"> Fixed stage with different inserts and object guide Manual 3-plate stage with different inserts Gliding stage 	<ul style="list-style-type: none"> Fixed stage with different inserts and object guide Manual 3-plate stage with different inserts Gliding stage 	<ul style="list-style-type: none"> Motorized 3-plate stage with different inserts Scanning stage with different inserts Manual 3-plate stage with different inserts Gliding stage
ILLUMINATION			
	<ul style="list-style-type: none"> LED Halogen (ext. power supply) 	<ul style="list-style-type: none"> LED Halogen (ext. power supply) EL6000 Hg 100 W (ext. power supply) 	<ul style="list-style-type: none"> LED Halogen (ext. power supply) EL6000 Hg 100 W (ext. power supply)

The statement by Ernst Leitz in 1907, “With the User, For the User,” describes the fruitful collaboration with end users and driving force of innovation at Leica Microsystems. We have developed five brand values to live up to this tradition: Pioneering, High-end Quality, Team Spirit, Dedication to Science, and Continuous Improvement. For us, living up to these values means: **Living up to Life.**

Leica Microsystems operates globally in three divisions, where we rank with the market leaders.

Leica Microsystems – an international company with a strong network of worldwide customer services:

LIFE SCIENCE DIVISION

The Leica Microsystems Life Science Division supports the imaging needs of the scientific community with advanced innovation and technical expertise for the visualization, measurement, and analysis of microstructures. Our strong focus on understanding scientific applications puts Leica Microsystems’ customers at the leading edge of science.

INDUSTRY DIVISION

The Leica Microsystems Industry Division’s focus is to support customers’ pursuit of the highest quality end result. Leica Microsystems provide the best and most innovative imaging systems to see, measure, and analyze the microstructures in routine and research industrial applications, materials science, quality control, forensic science investigation, and educational applications.

MEDICAL DIVISION

The Leica Microsystems Medical Division’s focus is to partner with and support surgeons and their care of patients with the highest-quality, most innovative surgical microscope technology today and into the future.

Active worldwide		Tel.	Fax
Australia · North Ryde	+61	2 8870 3500	2 9878 1055
Austria · Vienna	+43	1 486 80 50 0	1 486 80 50 30
Belgium · Diegem	+32	2 790 98 50	2 790 98 68
Brazil · São Paulo	+55	11 2764-2411	11 2764-2400
Canada · Concord/Ontario	+1	800 248 0123	847 405 0164
Denmark · Ballerup	+45	4454 0101	4454 0111
France · Nanterre Cedex	+33	811 000 664	1 56 05 23 23
Germany · Wetzlar	+49	64 41 29 40 00	64 41 29 41 55
India · Mumbai	+91	226 1880 200	226 1880 333
Italy · Milan	+39	02 574 861	02 574 03392
Japan · Tokyo	+81	3 6758 5630	3 5155 4333
Korea · Seoul	+82	2 514 65 43	2 514 65 48
Netherlands · Rijswijk	+31	70 4132 100	70 4132 109
People’s Rep. of China · Hong Kong	+852	2564 6699	2564 4163
· Shanghai	+86	21 6039 6000	21 6387 6698
Portugal · Lisbon	+351	21 388 9112	21 385 4668
Singapore	+65	6550 5999	6564 5955
Spain · Barcelona	+34	93 494 95 30	93 494 95 32
Sweden · Bromma	+46	8 625 45 45	8 625 45 10
Switzerland · Heerbrugg	+41	71 726 34 34	71 726 34 44
Turkey · Istanbul	+90	216 504 0100	216 504 0110
United Kingdom · Milton Keynes	+44	800 298 2344	1908 577640
USA · Buffalo Grove/Illinois	+1	800 248 0123	847 405 0164

